

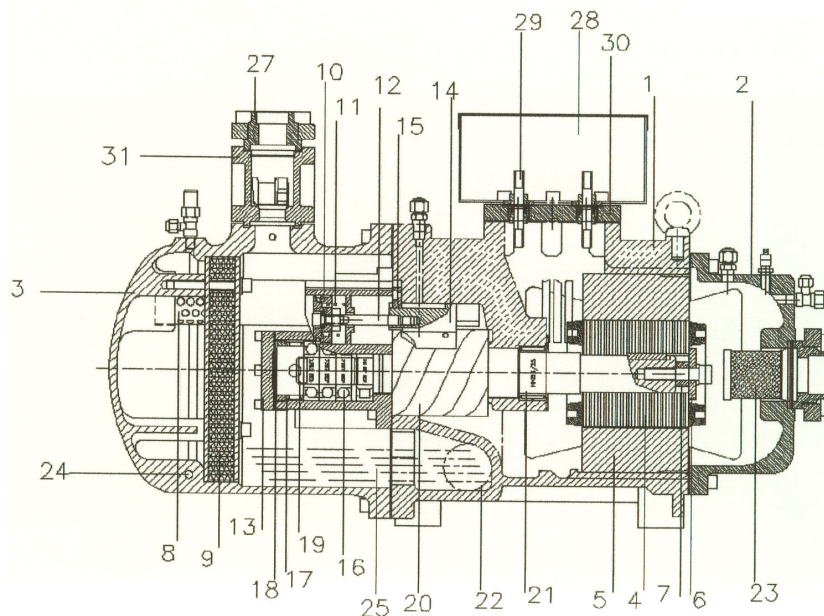

Package Water Chillers
dry-coolers heating pumps



NR.	DESCRIPTION	NR.	DESCRIPTION
1	Compressor casing	17	Discharge fixed ring
2	Motor casing	18	Disc spring
3	Oil separator	19	Bearing slot nut
4	Motor rotor assembly	20	Male rotor
5	Motor stator assembly	21	Suction bearings
6	Motor rotor washer	22	Oil filter cartridge
7	Motor rotor spacer ring	23	Suction filter
8	Baffle	24	Oil heater
9	Oil separator cartridge	25	Refrigeration lubricant
10	Piston	26	Suction flange
11	Piston spring	27	Discharge flange
12	Piston rod	28	Cable box
13	Bearing seat's cover plate	29	Power bolt
14	Modulation slide valve	30	Motor cable cover plate
15	Slide valve key	31	Check valve
16	Discharge bearings	32	

SERIE: SCREW CMP	COD. RC10	VERIFICATO
DATA: 25/05/06	SOST: /	M.BURBA

