

VISTA FRONTALE
FRONT VIEW

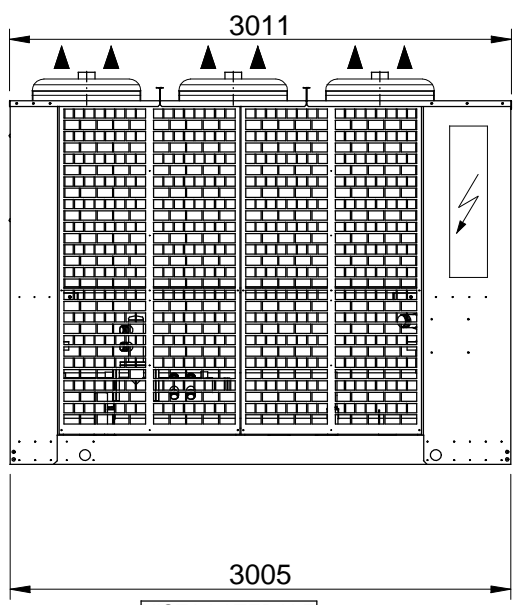

VISTA LATERALE
SIDE VIEW

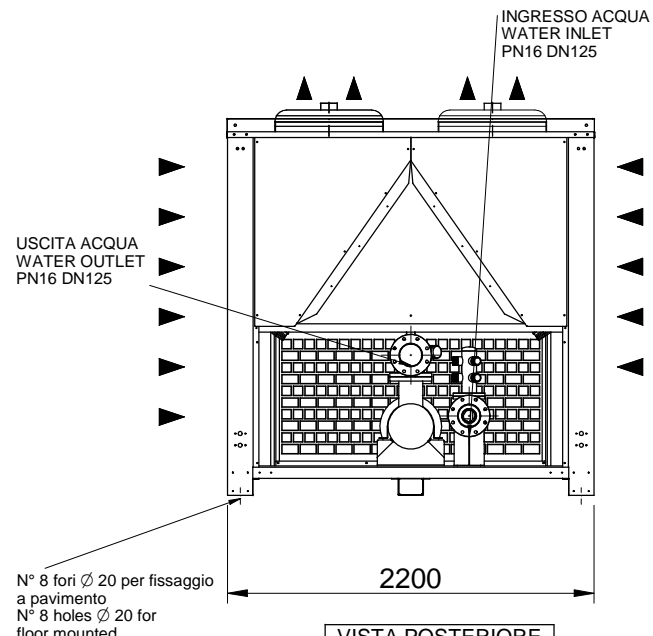

VISTA POSTERIORE
BACK VIEW

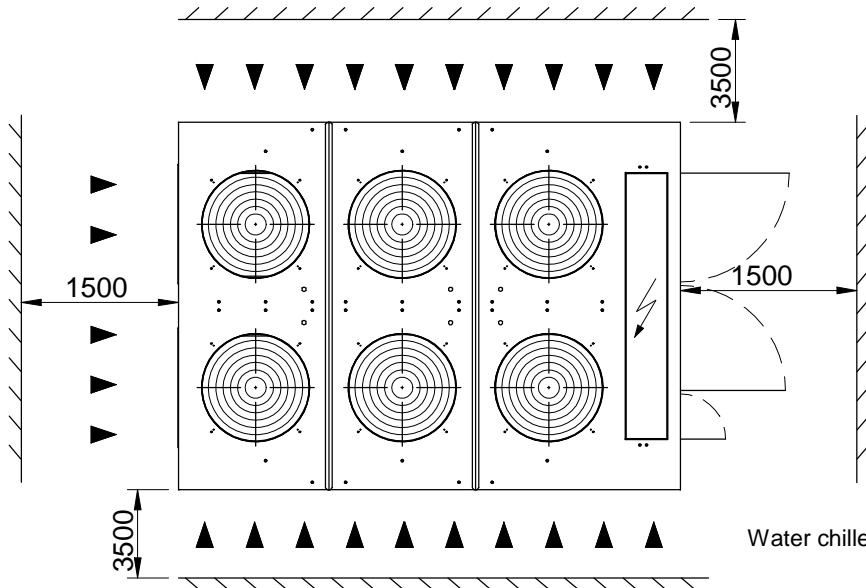

VISTA DALL'ALTO
TOP VIEW

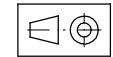

PESO - WEIGHT
- ECF230 3000 Kg.

Water chiller ECF series mod. ECF230

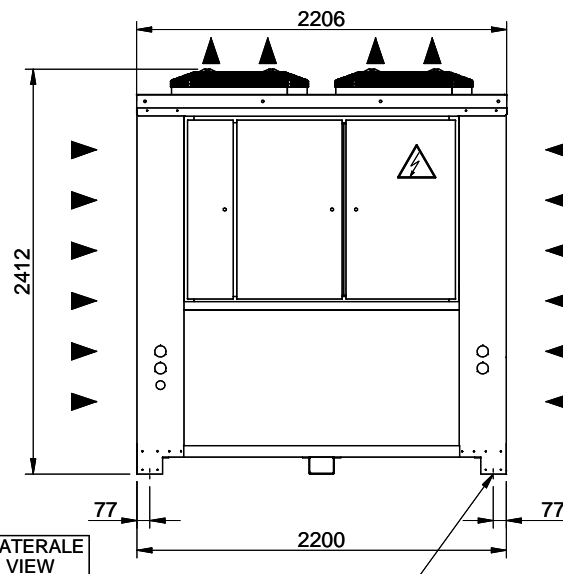
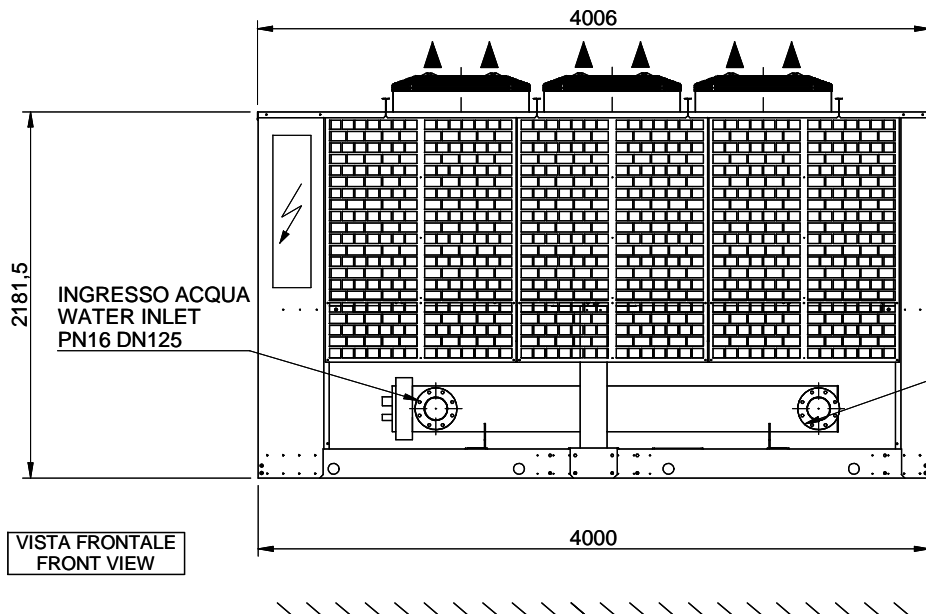

N°12 fori Ø20 per
fissaggio a pavimento
N°12 holes Ø20 for
the floor mounted

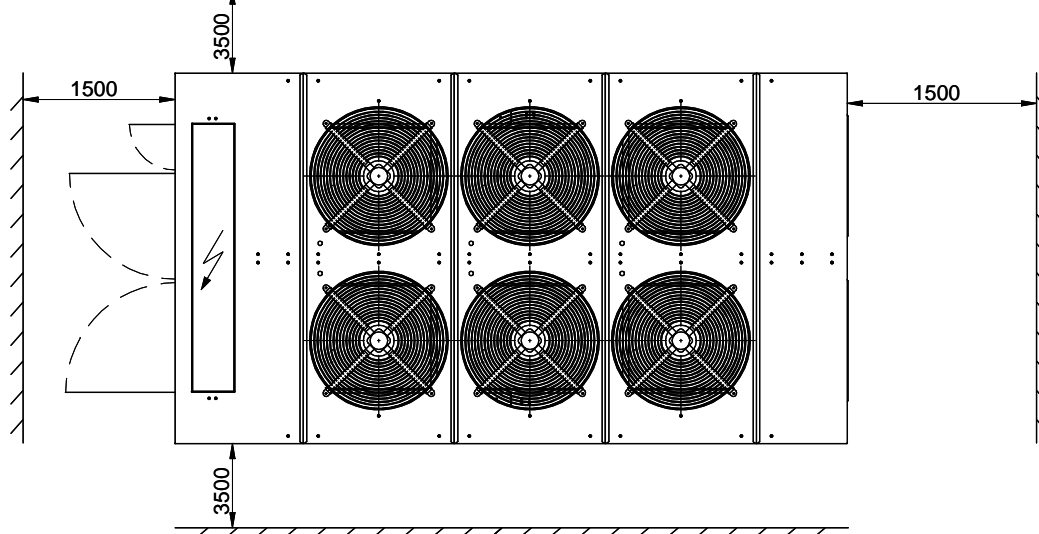

VISTA DALL'ALTO
TOP VIEW

PESO - WEIGHT
-ECF290 3700 kg.
-ECF320 3800 kg.

WATER CHILLERS series ECF mod. ECF.290-320



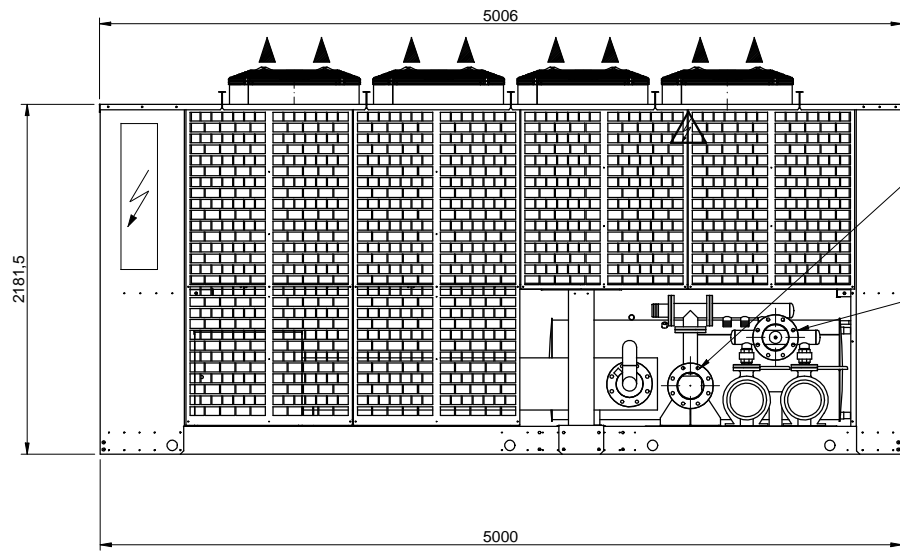

VISTA LATERALE
SIDE VIEW

INGRESSO ACQUA
WATER INLET
PN16 DN150

USCITA ACQUA
WATER OUTLET
PN16 DN150

N°4 fori Ø22 per
fissaggio a pavimento

N°4 holes Ø22 for
the floor mounted

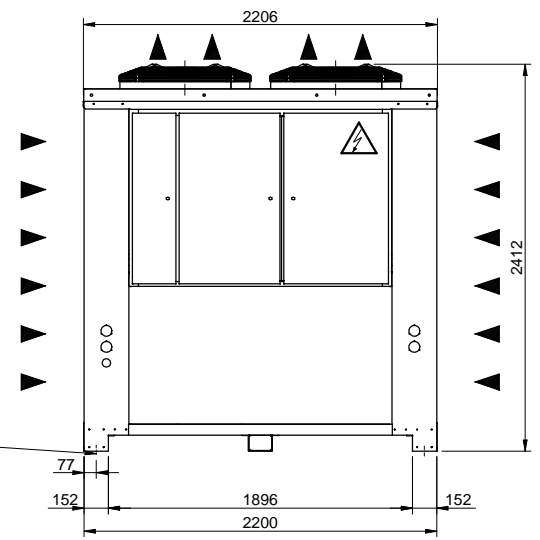

VISTA FRONTALE
FRONT VIEW

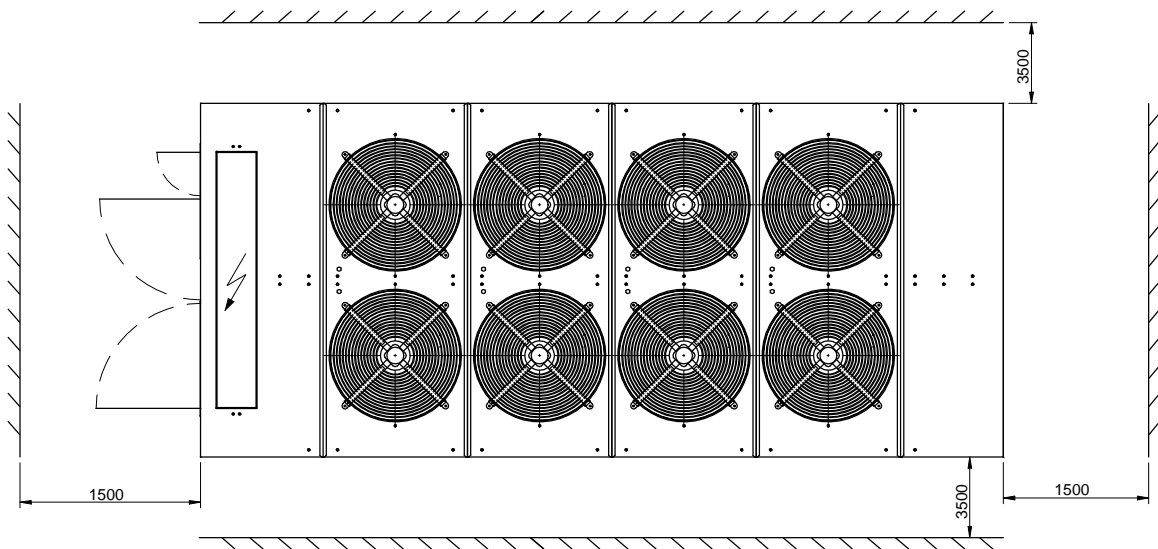

VISTA DALL'ALTO
TOP VIEW

PESO - WEIGHT
-ECF370 4500 kg.
-ECF425 4700 kg.

WATER CHILLERS series ECF mod. ECF.370-425

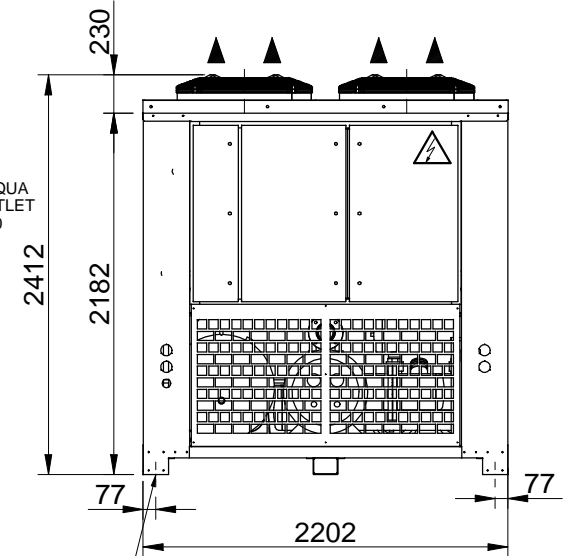
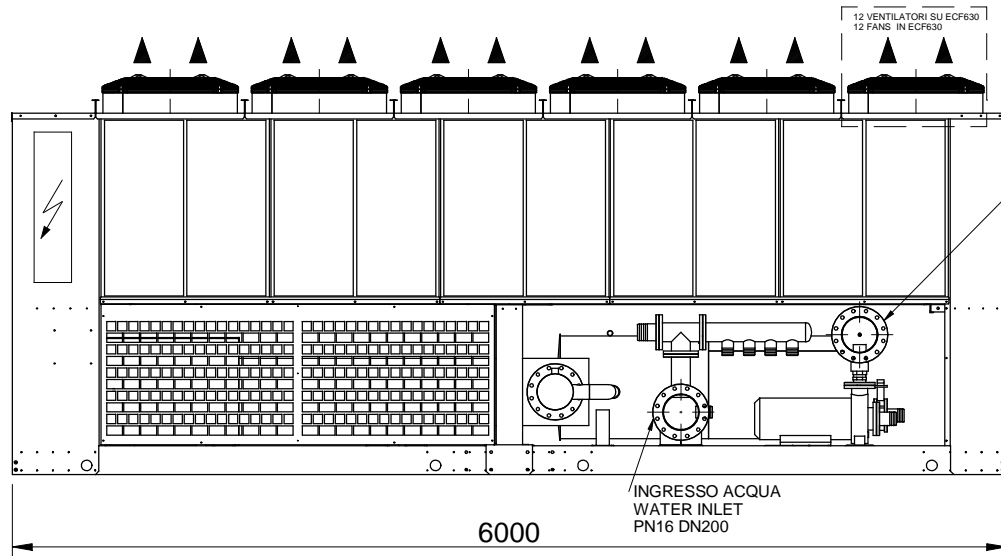

VISTA LATERALE
SIDE VIEW

VISTA FRONTALE
FRONT VIEW

N° 16 fori Ø 20 per fissaggio
a pavimento
N° 16 holes Ø 20 for
floor mounted

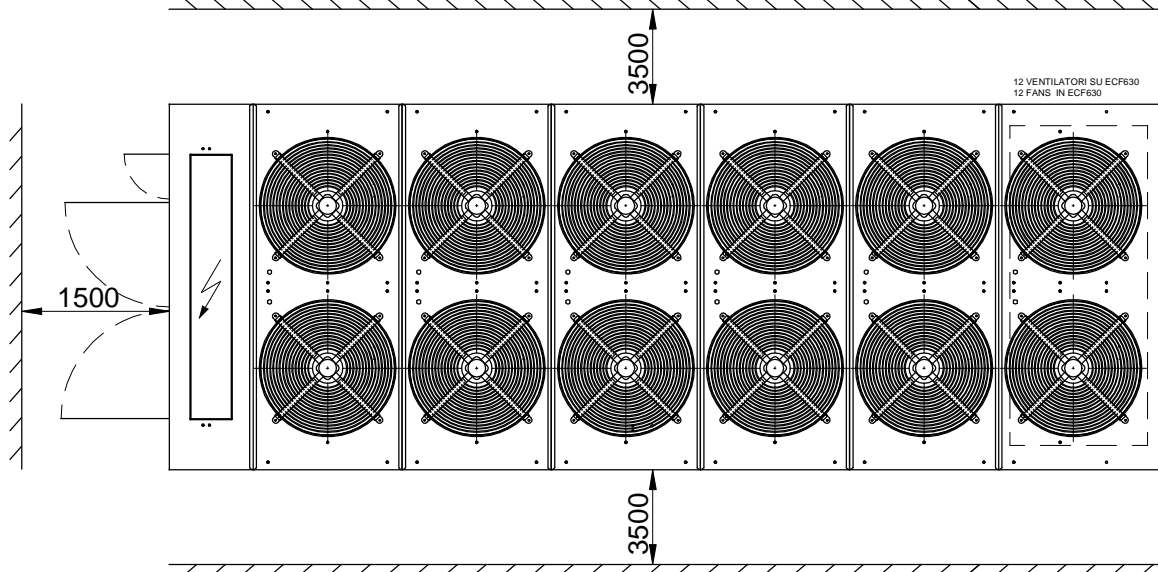

VISTA DALL'ALTO
TOP VIEW

- ECF545 10 VENTILATORI / FANS
 - ECF630 12 VENTILATORI / FANS
- PESO - WEIGHT**
 - ECF545 6000 kg.
 - ECF630 6300 kg.

Big water chiller ECF series mod. ECF545-630

VISTA LATERALE
SIDE VIEW

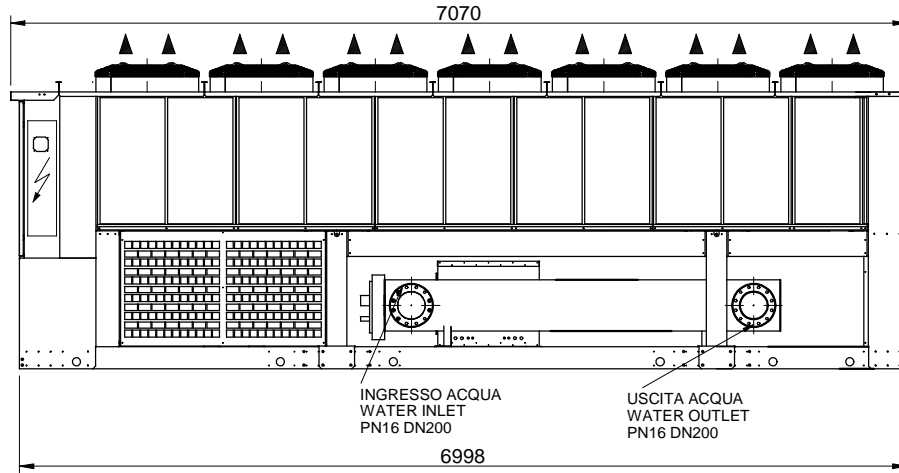

VISTA FRONTALE
FRONT VIEW

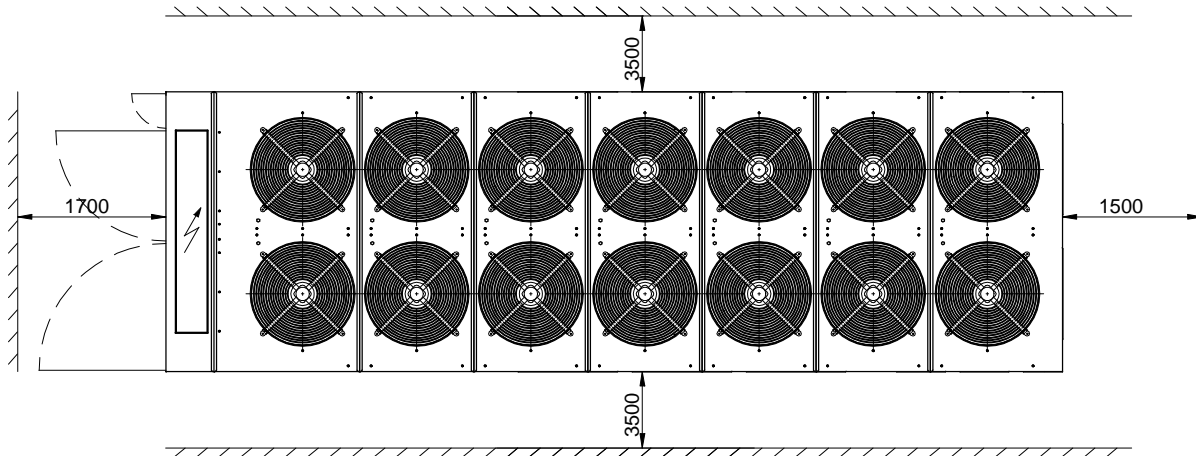
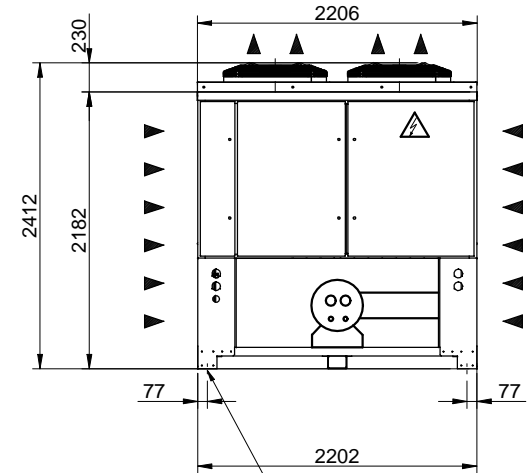

VISTA DALL'ALTO
TOP VIEW



PESO - WEIGHT
- ECF750 7000 Kg.

Water chiller ECF series mod. ECF750

VISTA LATERALE
SIDE VIEW

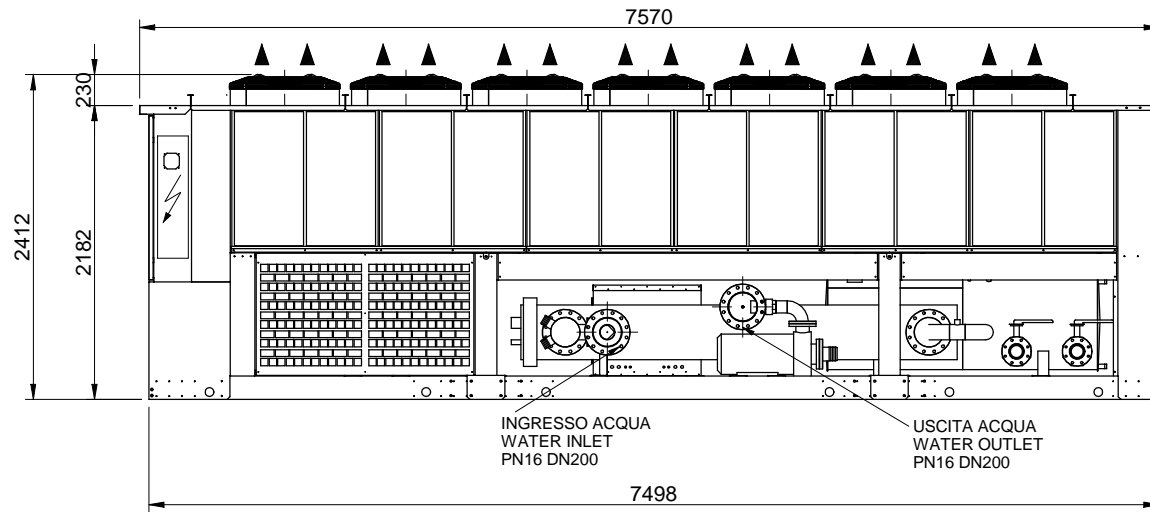

VISTA FRONTALE
FRONT VIEW

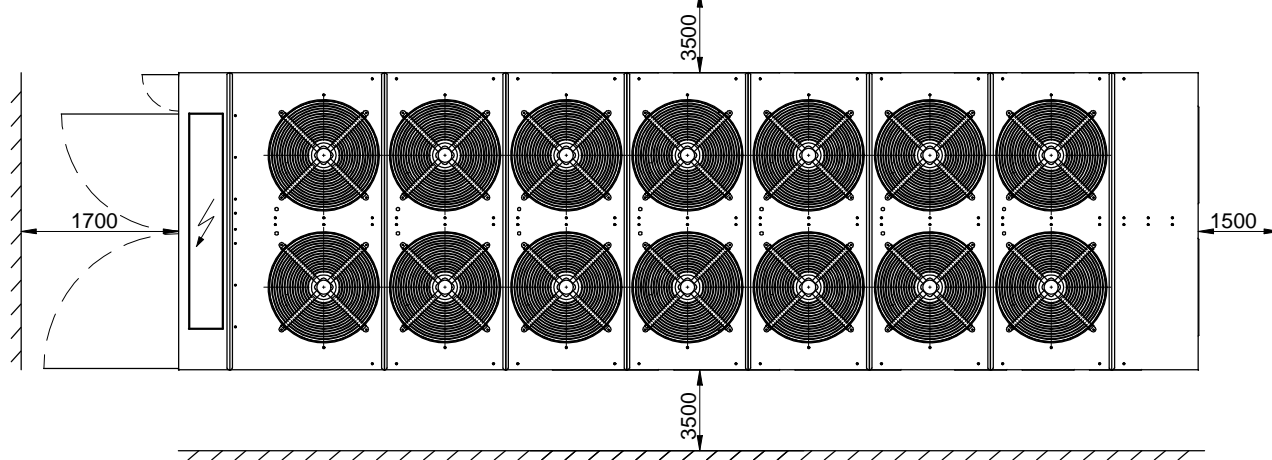
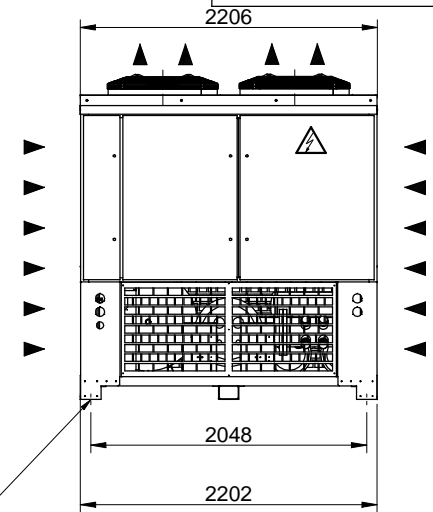

VISTA DALL'ALTO
TOP VIEW

Water chiller ECF series mod. ECF840



PESO - WEIGHT
7500 Kg.