

VISTA FRONTALE
FRONT VIEW

ATTACCO PORTAGOMMA Ø12
ATTACK PIPE TUBE Ø12

N°4 fori Ø9 per
fissaggio a pavimento

N°4 holes Ø9 for
the floor mounted

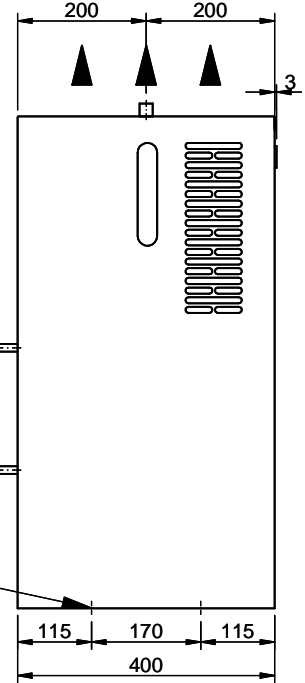

VISTA LATERALE
SIDE VIEW

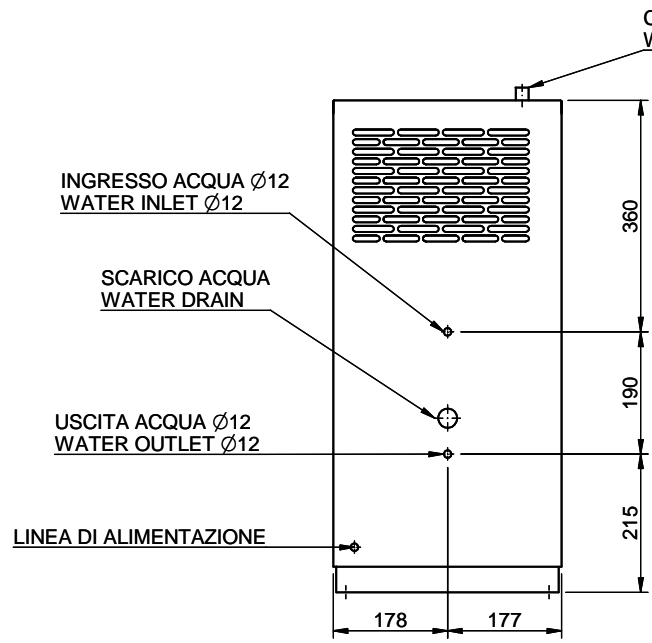

VISTA POSTERIORE
BACK VIEW

VISTA DALL'ALTO
TOP VIEW

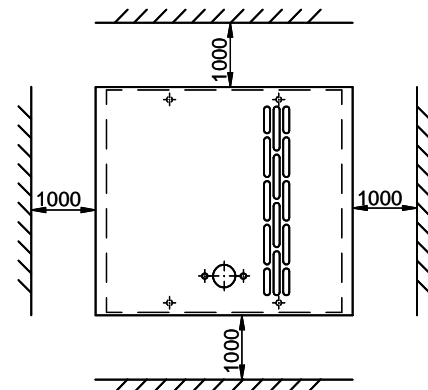

PESO - WEIGHT
33 Kg.

REFRIGERATORE D'ACQUA / WATER CHILLER MOD. ECA.001
DIMENSIONI D'INGOMBRO / OVERALL DIMENSIONS

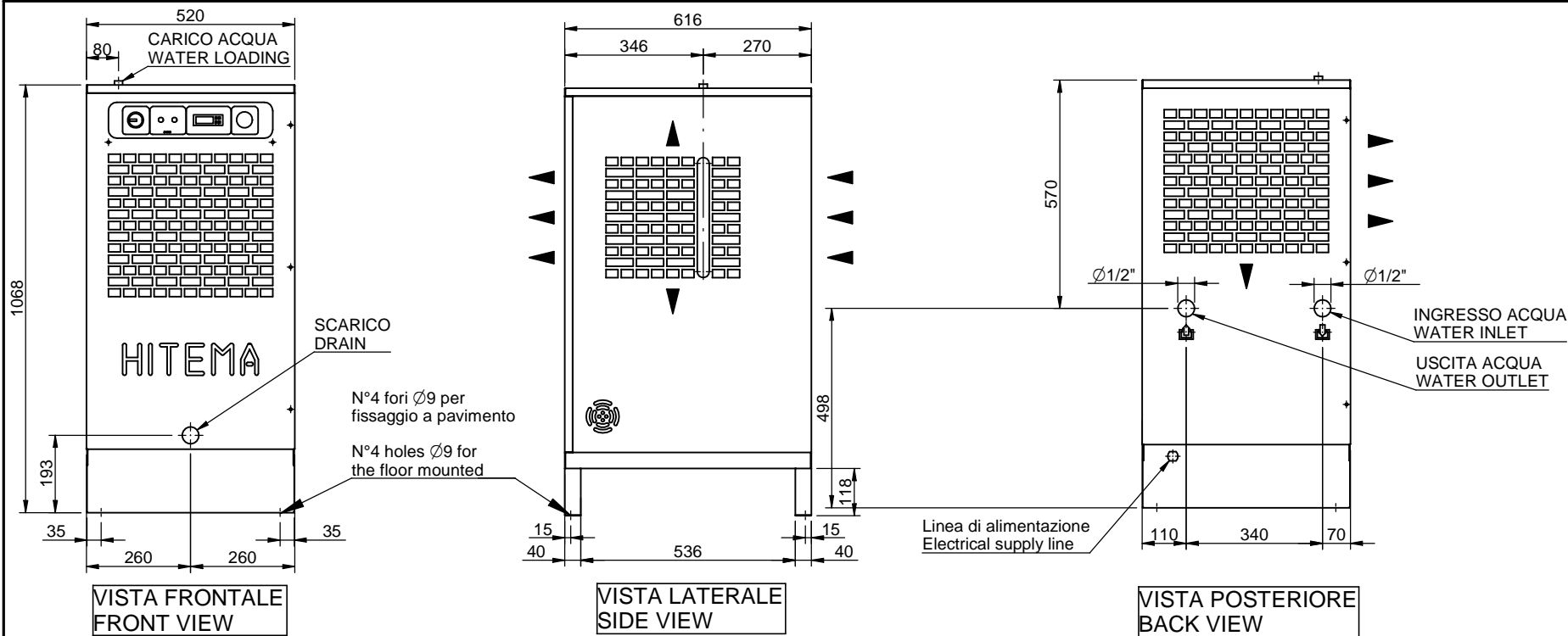

VISTA DALL'ALTO / TOP VIEW

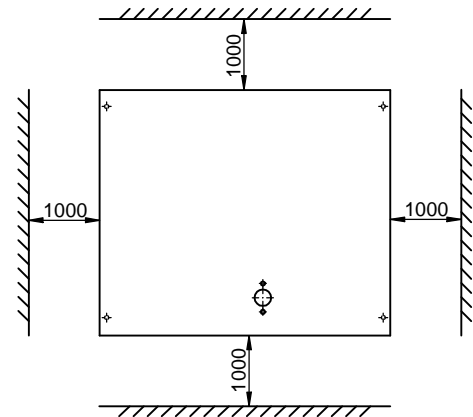

PESO - WEIGHT
110 Kg

REFRIG. D'ACQUA / WATER CHILLERS MOD. ECA.002-ECA.003-ECA.004
DIMENSIONI D'INGOMBRO / OVERALL DIMENSIONS

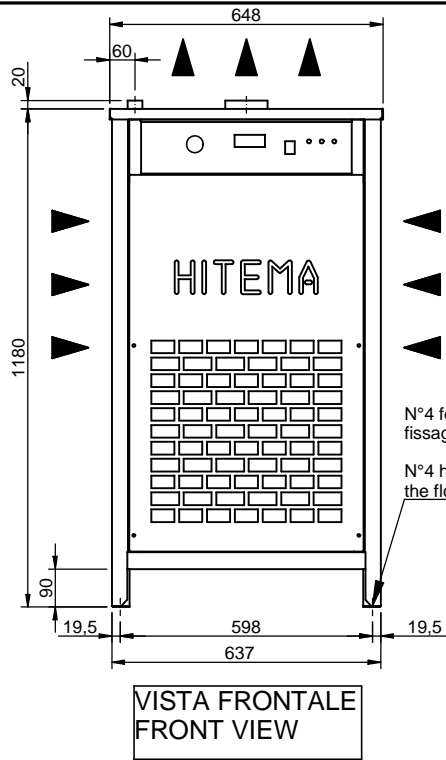

N°4 fori Ø10 per
fissaggio a pavimento
N°4 holes Ø10 for
the floor mounted

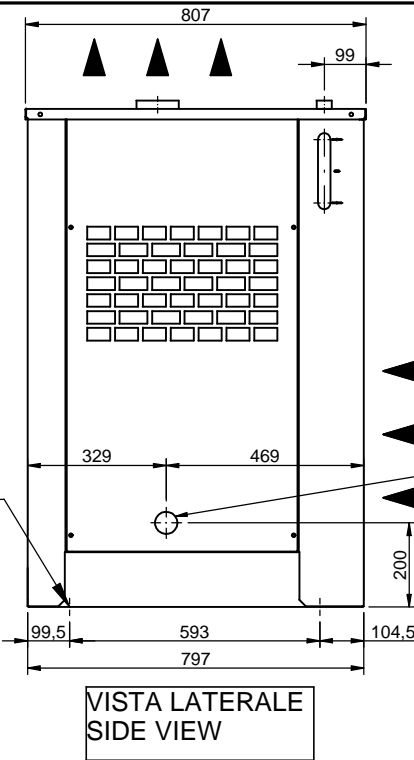

SCARICO ACQUA Ø1"
WATER DRAIN Ø1"

USCITA ACQUA Ø1"
WATER OUTLET Ø1"

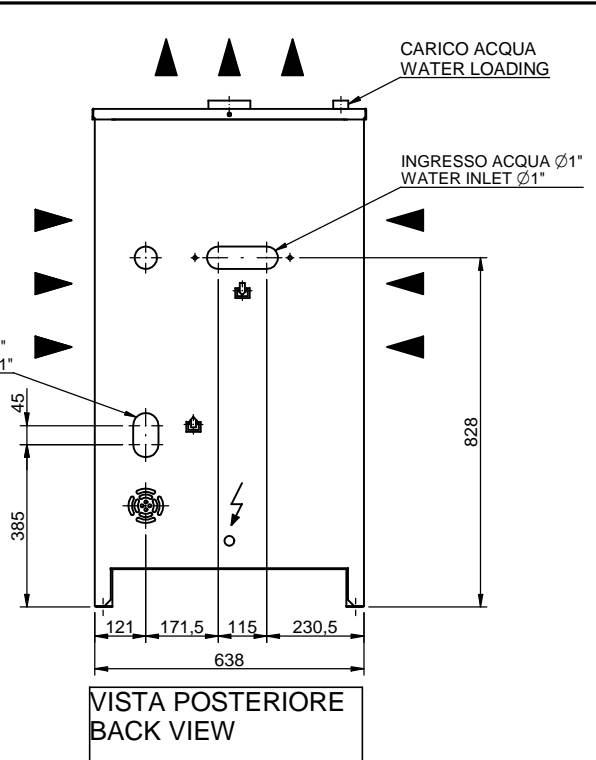

CARICO ACQUA
WATER LOADING

INGRESSO ACQUA Ø1"
WATER INLET Ø1"

VISTA DALL'ALTO
TOP VIEW

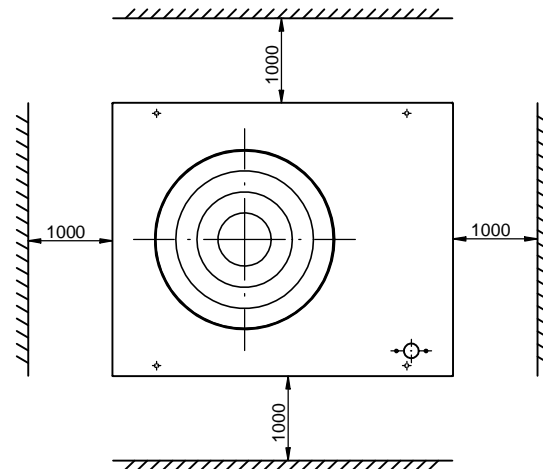

PESO - WEIGHT
230 Kg.

REFRIG.D'ACQUA / WATER CHILLER mod. ECA.005/CHP - ECA.008/CHP

DIMENSIONI D'INGOMBRO / OVERALL DIMENSIONS

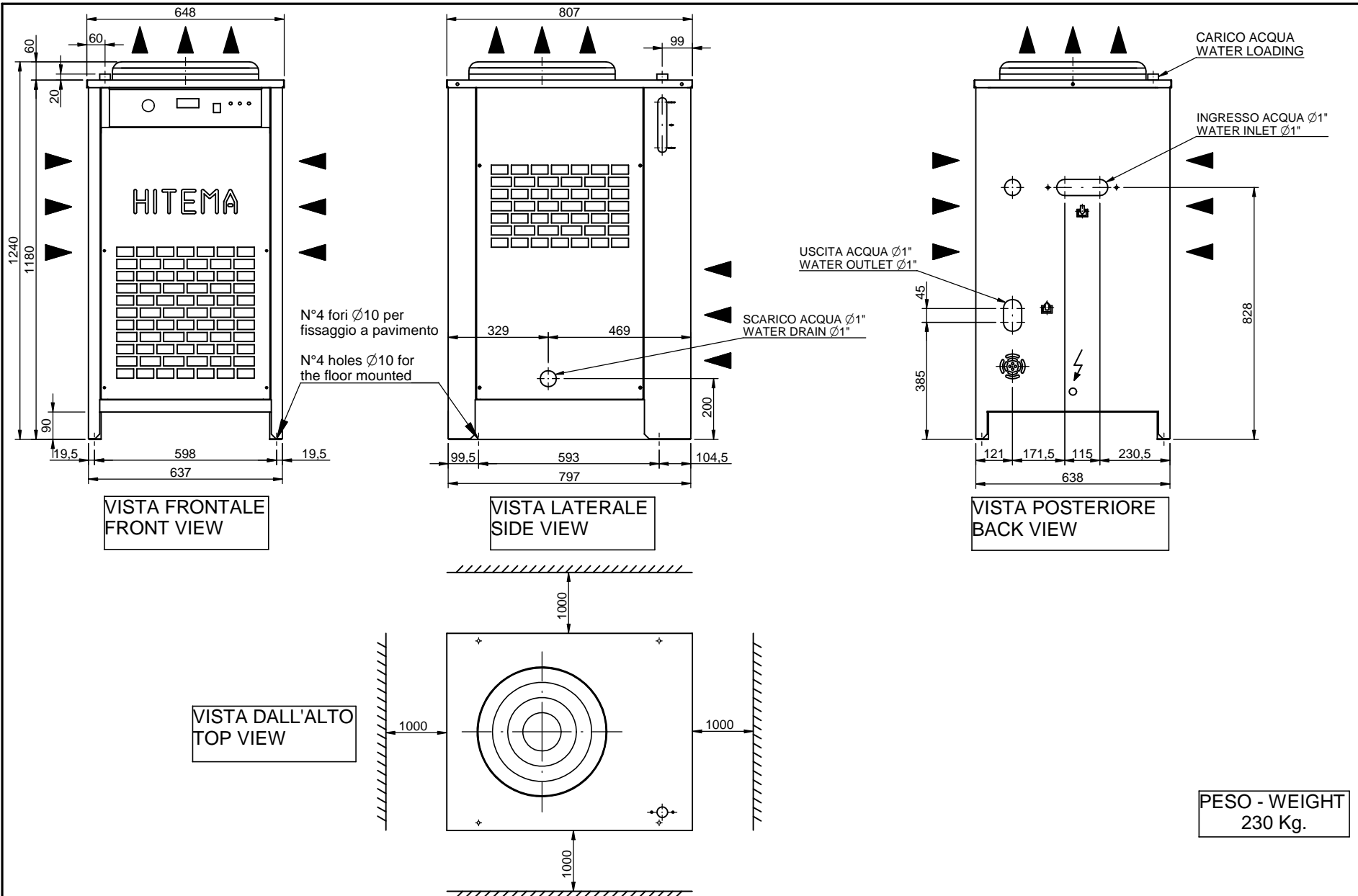

PESO - WEIGHT
230 Kg.

REFRIGERATORE D'ACQUA / WATER CHILLER mod. ECA.010/CHP
DIMENSIONI D'INGOMBRO / OVERALL DIMENSIONS

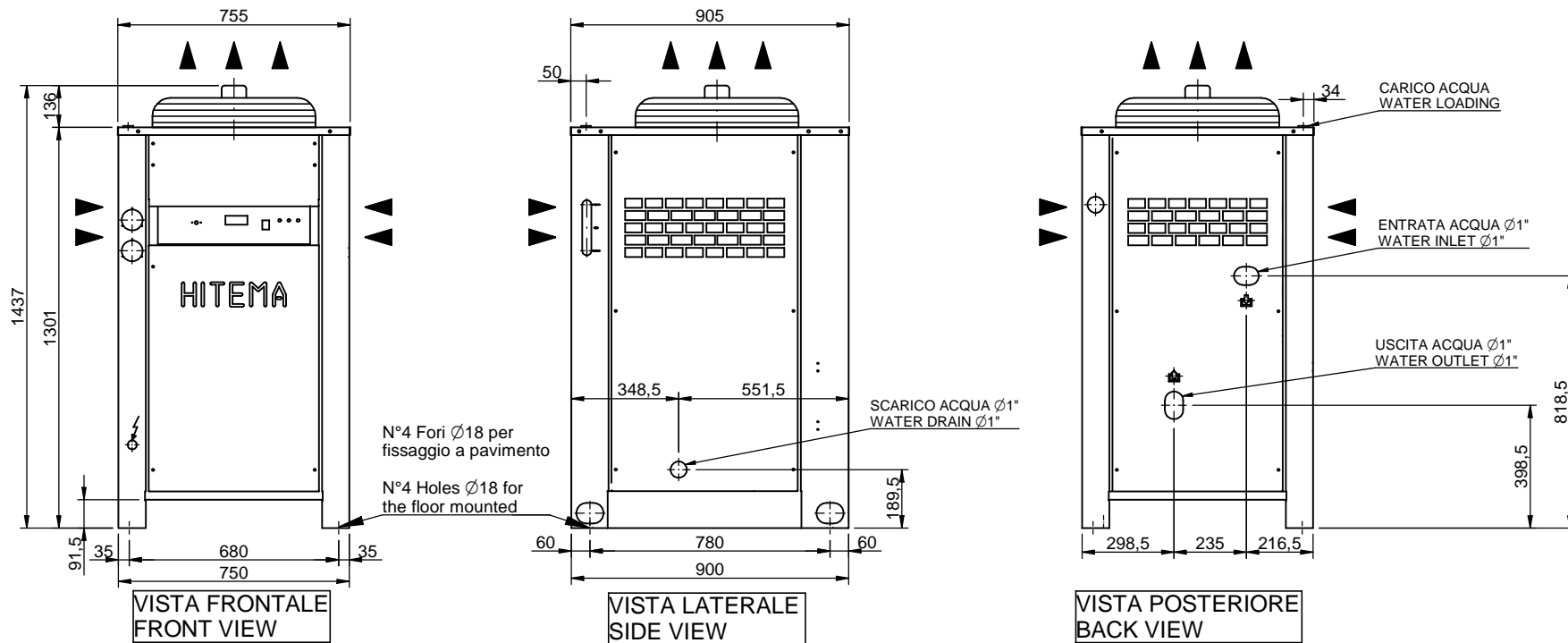

VISTA DALL'ALTO TOP VIEW

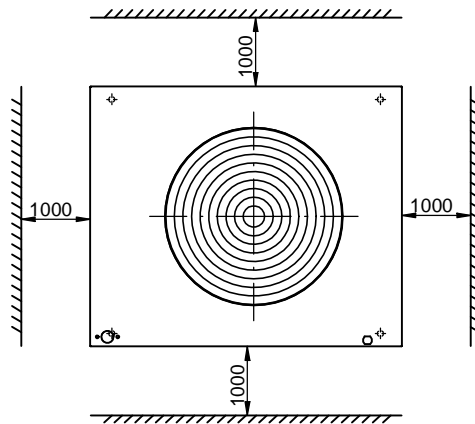

PESO - WEIGHT
250 Kg.

REFRIG.D'ACQUA / WATER CHILLER mod. ECA.012 /CHP - ECA.016 /CHP

DIMENSIONI D'INGOMBRO / OVERALL DIMENSIONS

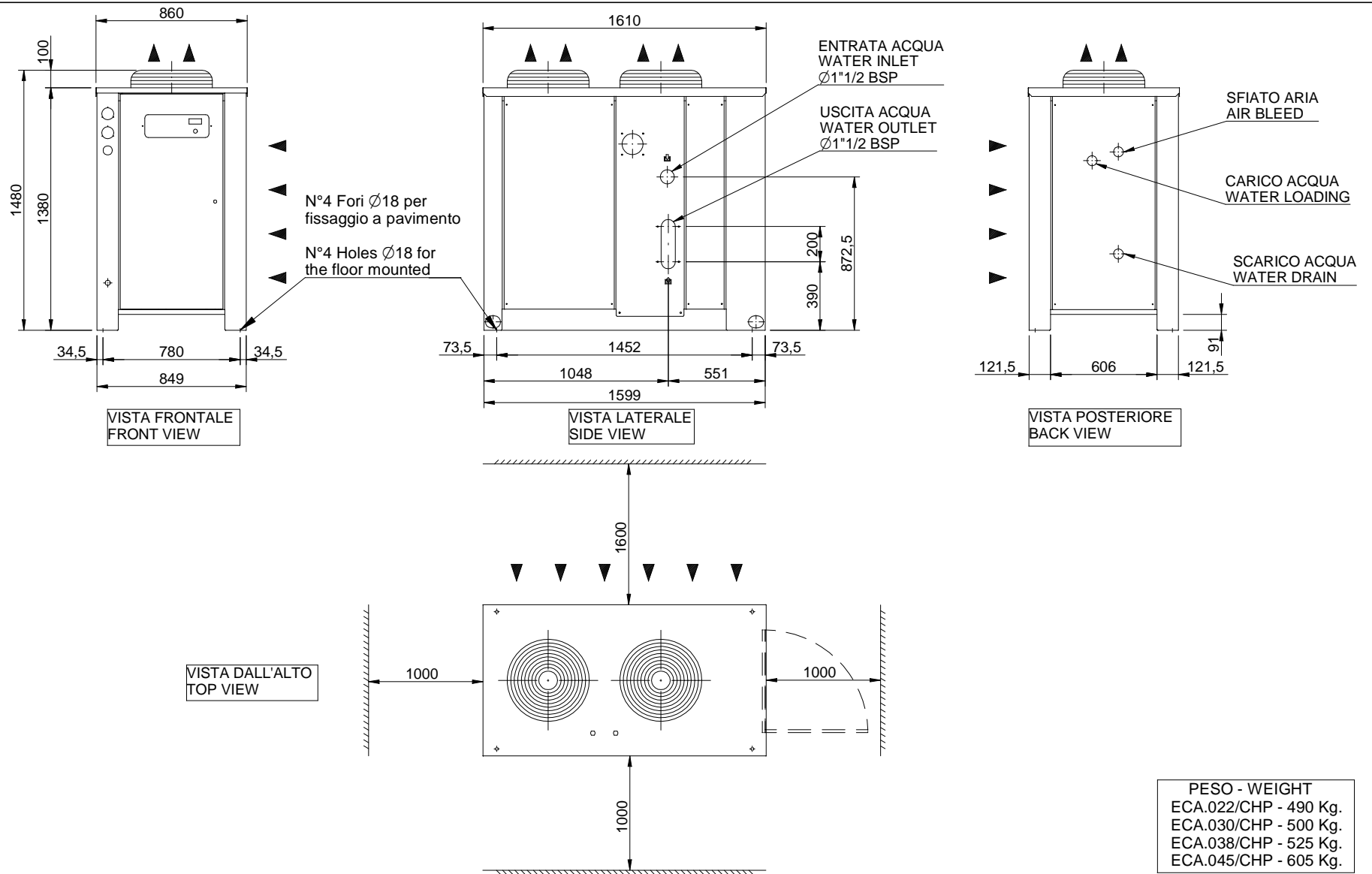

REFRIG.D'ACQUA / WATER CHILLERS mod. ECA.022 - 030 - 038 - 045/CHP

DIMENSIONI D'INGOMBRO / OVERALL DIMENSIONS

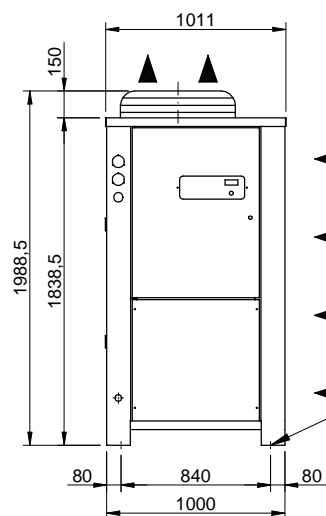

VISTA FRONTALE
FRONT VIEW

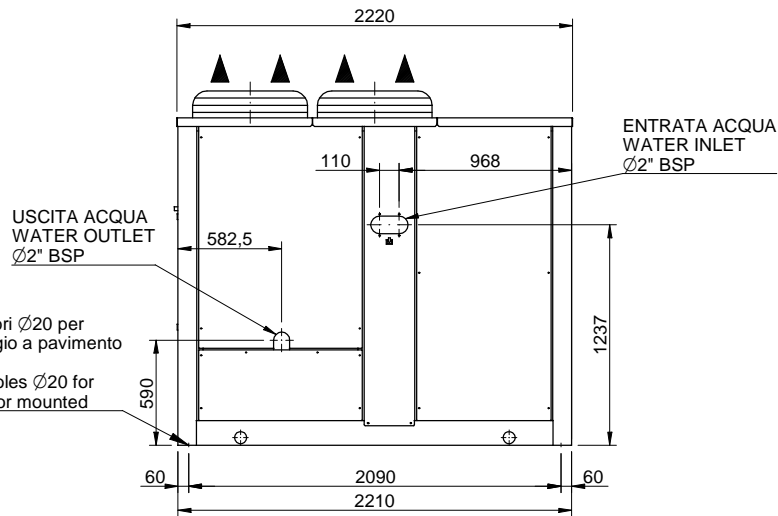

VISTA LATERALE
SIDE VIEW

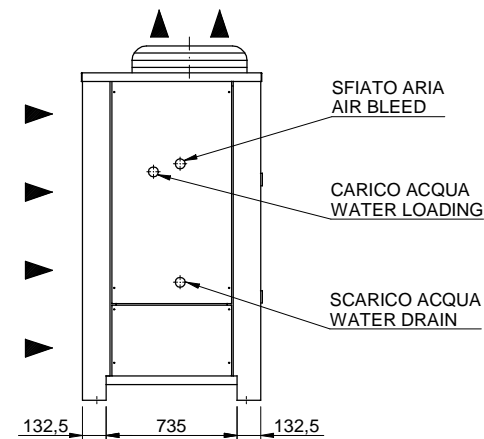

VISTA POSTERIORE
BACK VIEW

VISTA DALL'ALTO
TOP VIEW

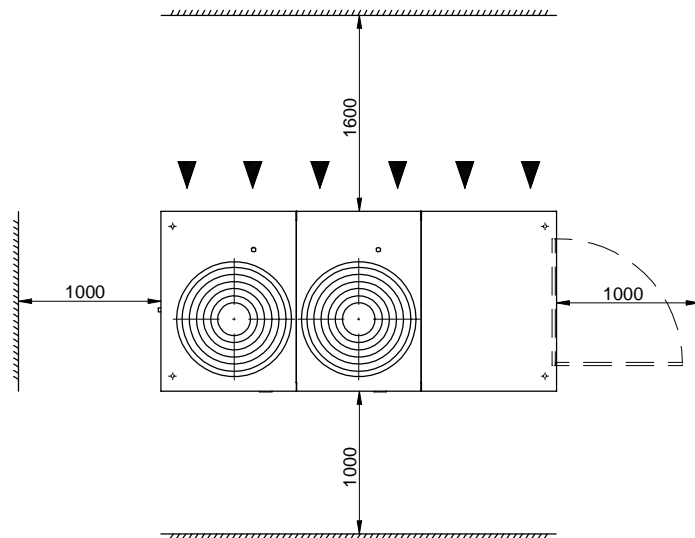

PESO - WEIGHT
 ECA.061/CHP 900 Kg.
 ECA.075/CHP 1050 Kg.

REFRIG. D'ACQUA / WATER CHILLERS mod. ECA.061/CHP - ECA.075/CHP
 DIMENSIONI D'INGOMBRO / OVERALL DIMENSIONS

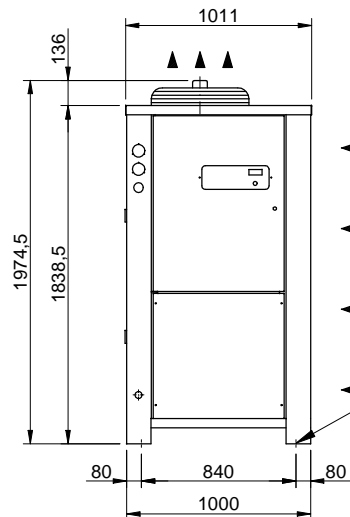

VISTA FRONTALE
FRONT VIEW

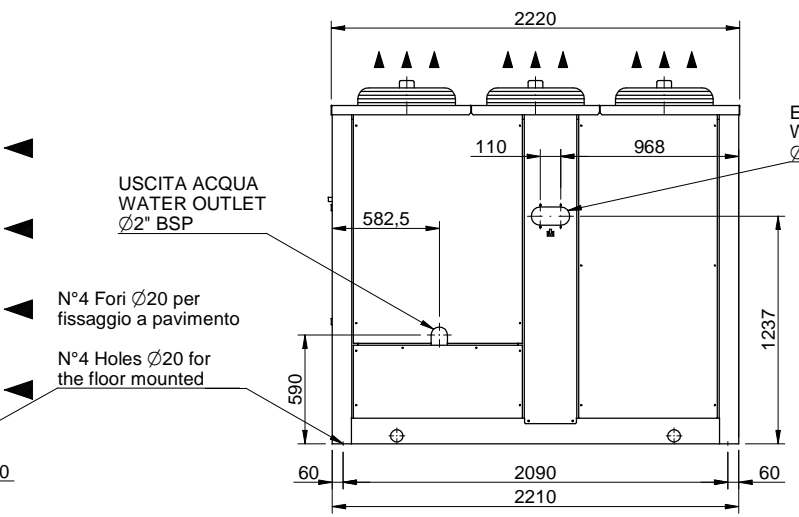

VISTA LATERALE
SIDE VIEW

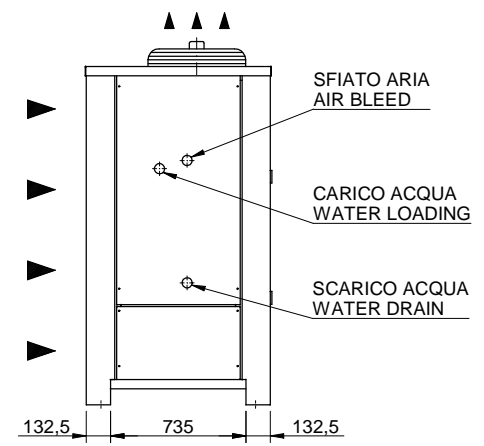

VISTA POSTERIORE
BACK VIEW

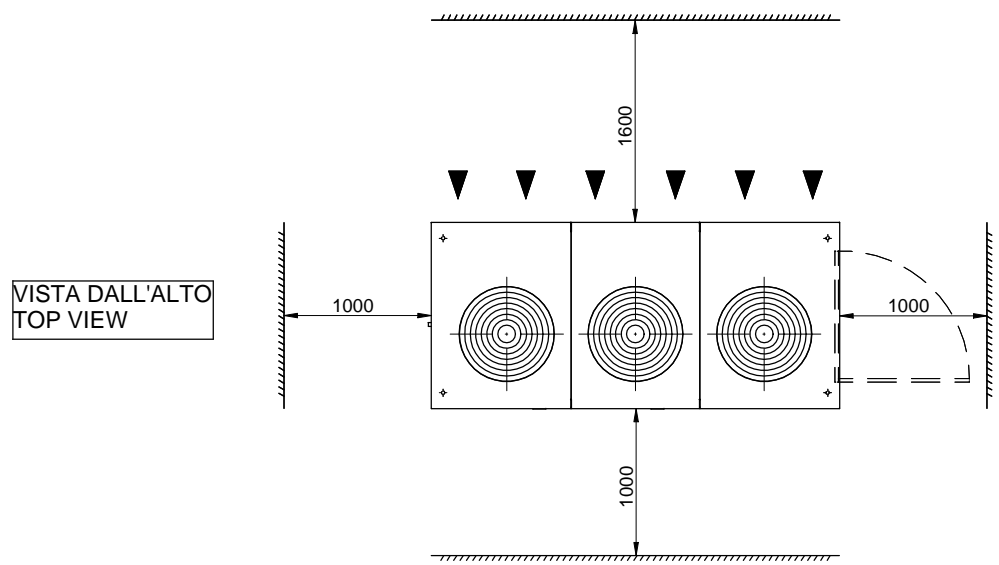

VISTA DALL'ALTO
TOP VIEW

PESO - WEIGHT
ECA.085/CHP 1150 Kg.

REFRIGERATORE D'ACQUA / WATER CHILLER mod. ECA.085/CHP
DIMENSIONI D'INGOMBRO / OVERALL DIMENSIONS

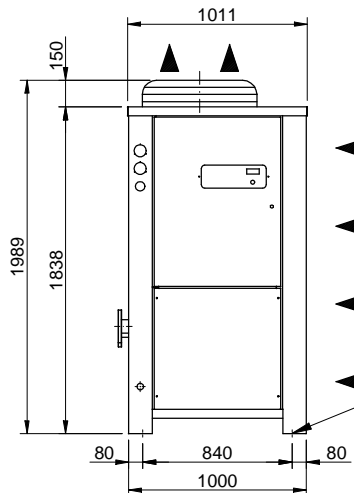

VISTA FRONTALE
FRONT VIEW

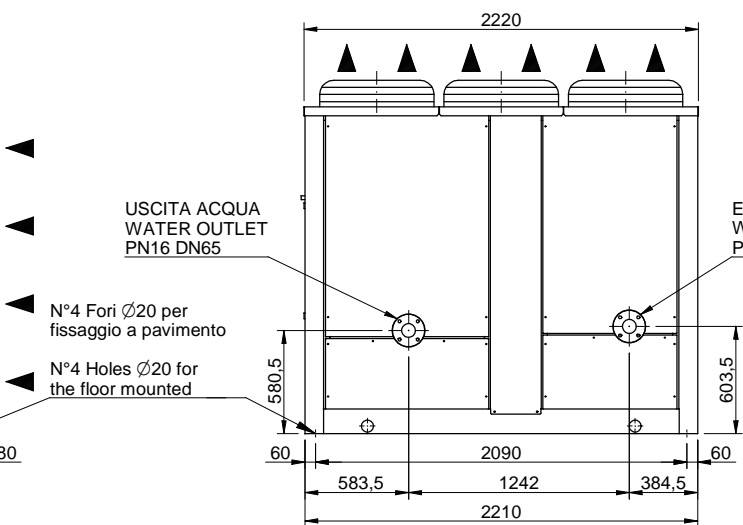

VISTA LATERALE
SIDE VIEW

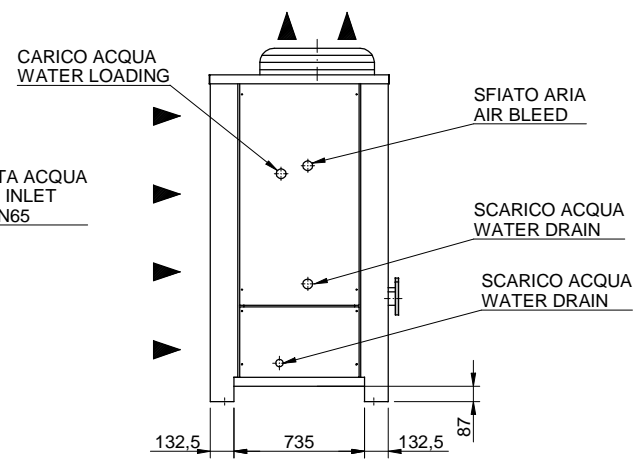

VISTA POSTERIORE
BACK VIEW

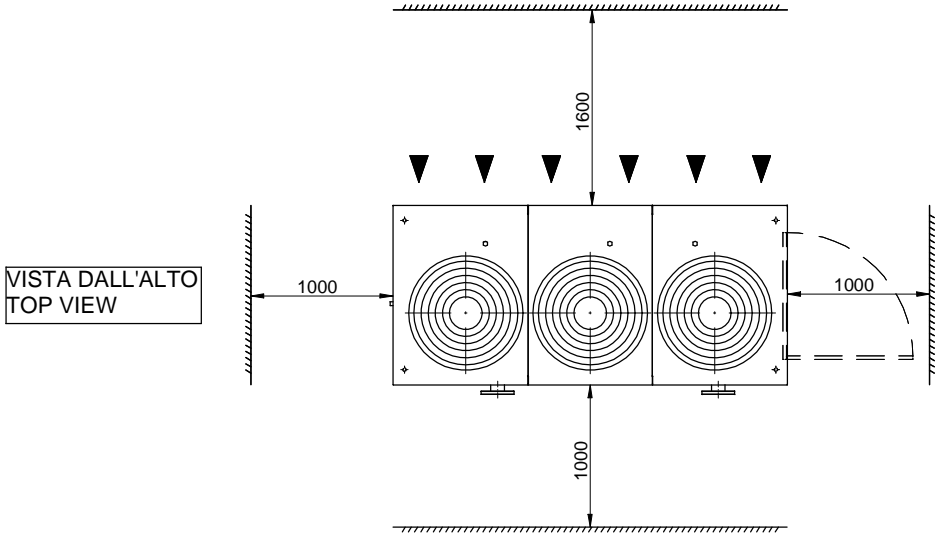

VISTA DALL'ALTO
TOP VIEW

PESO - WEIGHT
1200 Kg.

REFRIGERATORE D'ACQUA / WATER CHILLER mod. ECA.095/CHP
DIMENSIONI D'INGOMBRO / OVERALL DIMENSIONS

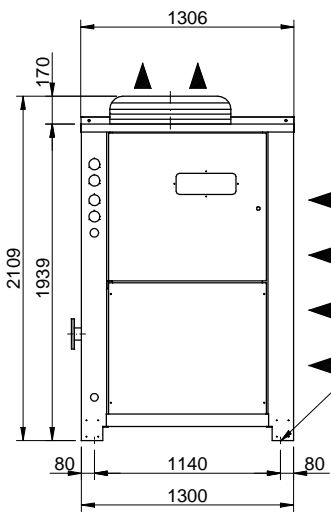

VISTA FRONTALE
FRONT VIEW

USCITA ACQUA
WATER OUTLET
PN 16 DN65

N°4 Fori $\varnothing 20$ per
fissaggio a pavimento

N°4 Holes $\varnothing 20$ for
the floor mounted

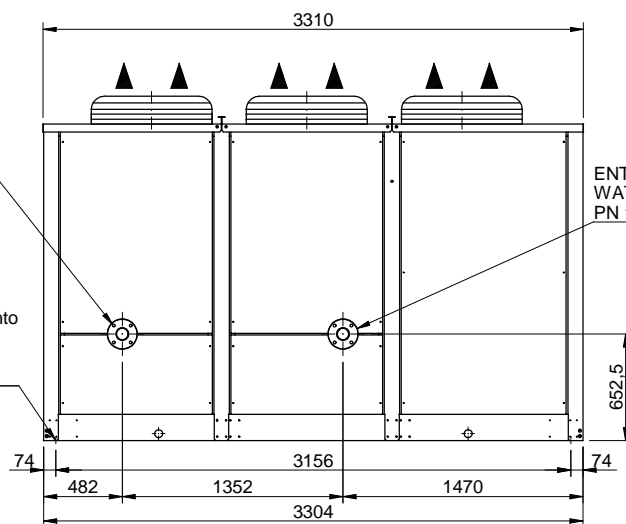

VISTA LATERALE
SIDE VIEW

ENTRATA ACQUA
WATER INLET
PN 16 DN65

CARICO ACQUA
WATER LOADING

SFIATO ARIA
AIR BLEED

SCARICO ACQUA
WATER DRAIN

SCARICO ACQUA
WATER DRAIN

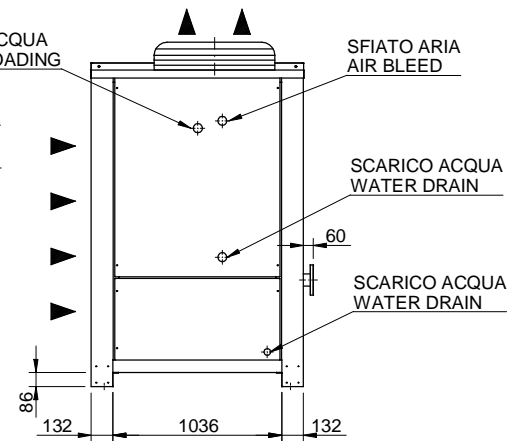

VISTA POSTERIORE
BACK VIEW

VISTA DALL'ALTO
TOP VIEW

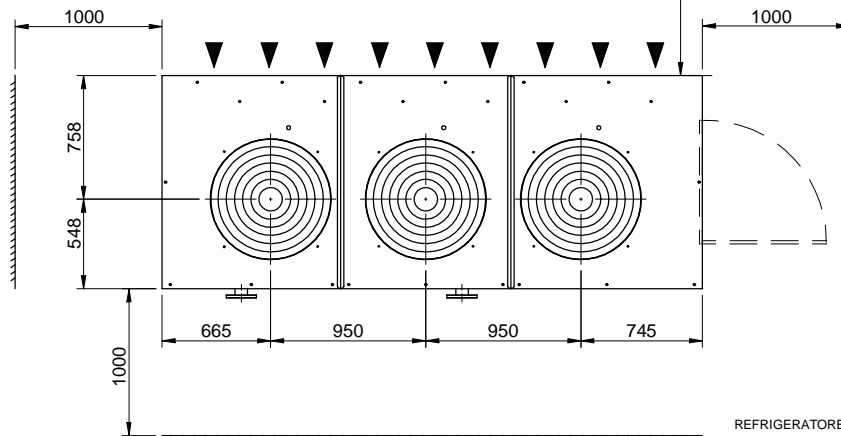

PESO - WEIGHT
1430 Kg.

REFRIGERATORE D'ACQUA / WATER CHILLER mod. ECA.120/CS STT
DIMENSIONI D'INGOMBRO / OVERALL DIMENSIONS

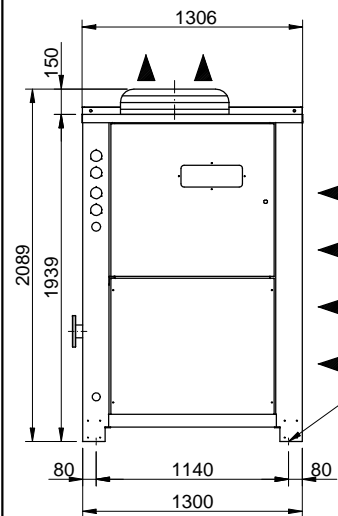

VISTA FRONTALE
FRONT VIEW

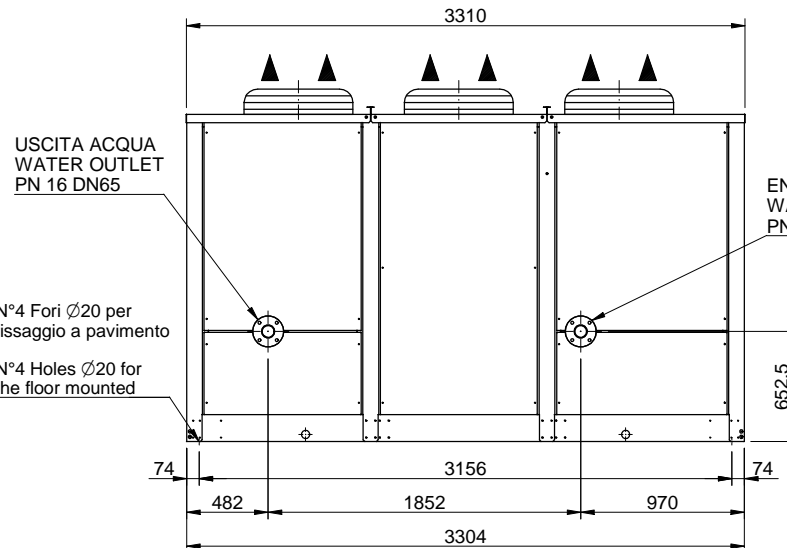

VISTA LATERALE
SIDE VIEW

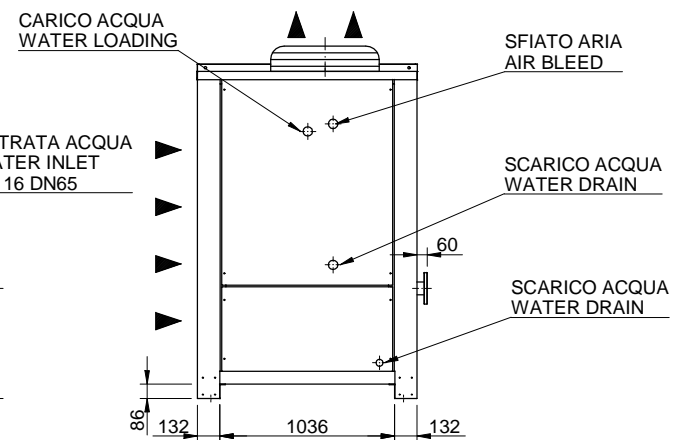

VISTA POSTERIORE
BACK VIEW

VISTA DALL'ALTO
TOP VIEW

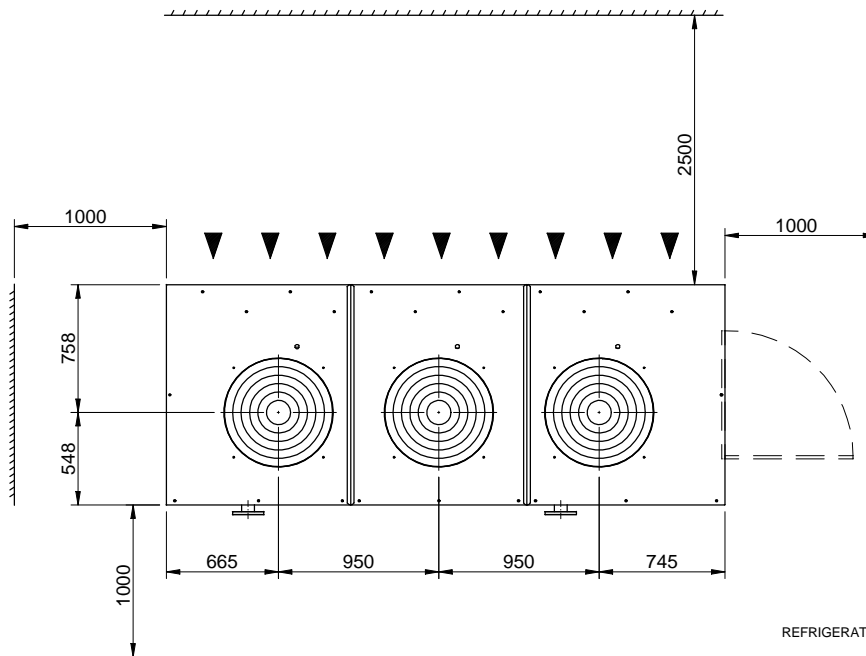

PESO - WEIGHT
1470 Kg.

REFRIGERATORE D'ACQUA / WATER CHILLER mod. ECA.150/CS STT
DIMENSIONI D'INGOMBRO / OVERALL DIMENSIONS

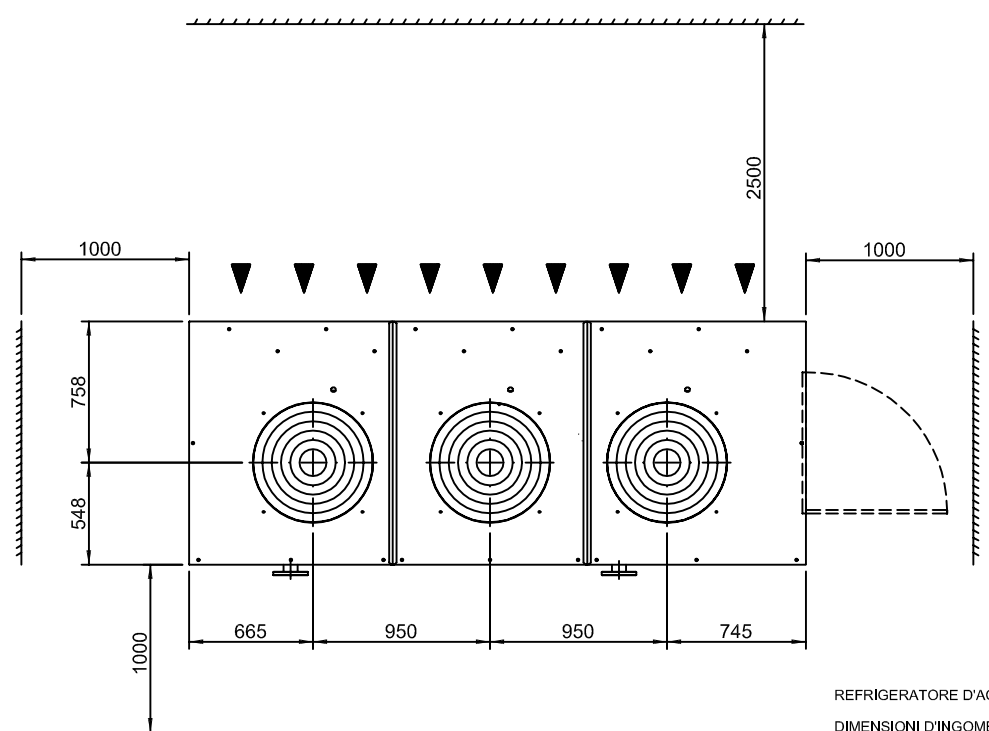
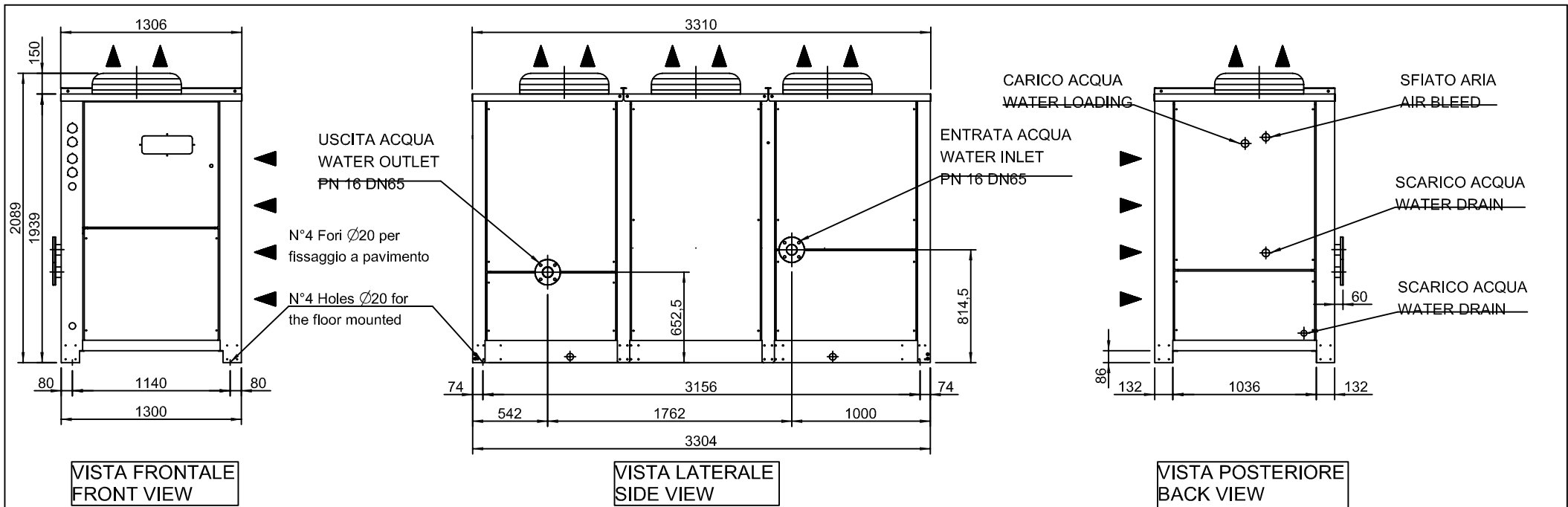

PESO - WEIGHT
1650 Kg.

REFRIGERATORE D'ACQUA / WATER CHILLER mod. ECA.180/CS STT
DIMENSIONI D'INGOMBRO / OVERALL DIMENSIONS

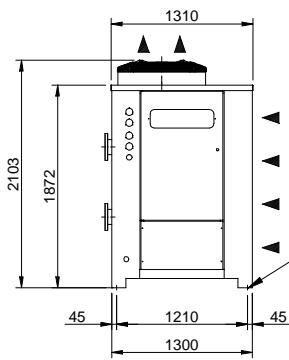

VISTA FRONTALE
FRONT VIEW

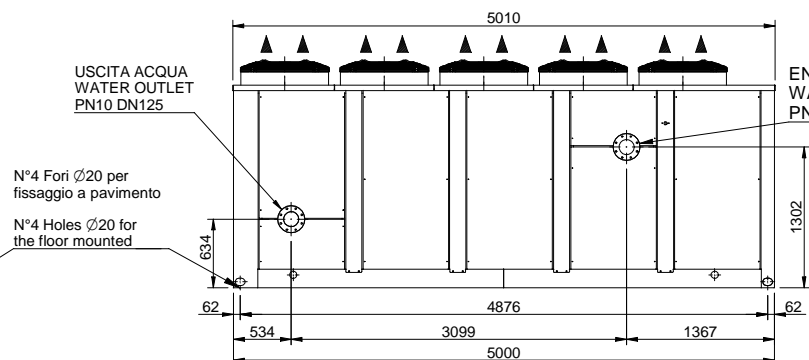

VISTA LATERALE
SIDE VIEW

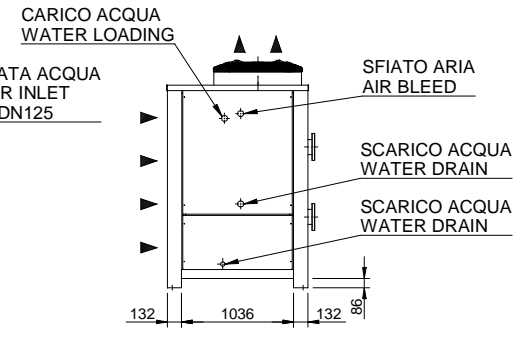

VISTA POSTERIORE
BACK VIEW

VISTA DALL'ALTO
TOP VIEW

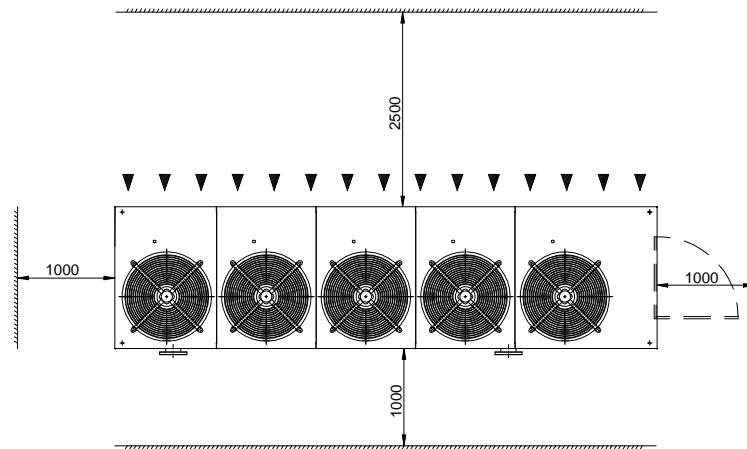

PESO - WEIGHT
2280 Kg.

REFRIGERATORE D'ACQUA / WATER CHILLER mod. ECA.210/CS STT
DIMENSIONI D'INGOMBRO / OVERALL DIMENSIONS

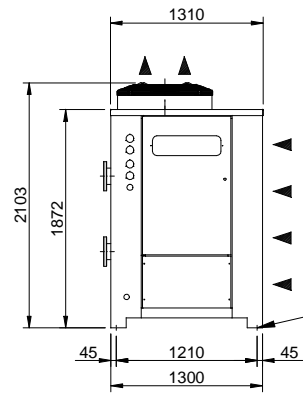

VISTA FRONTALE
FRONT VIEW

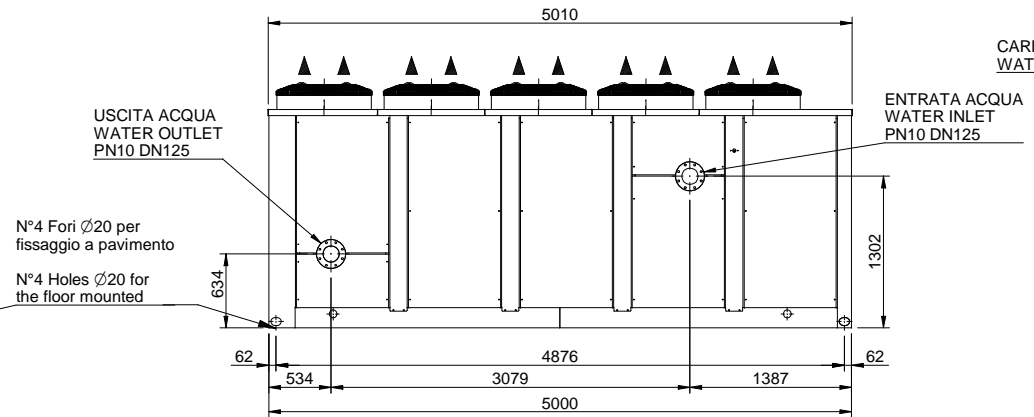

VISTA LATERALE
SIDE VIEW

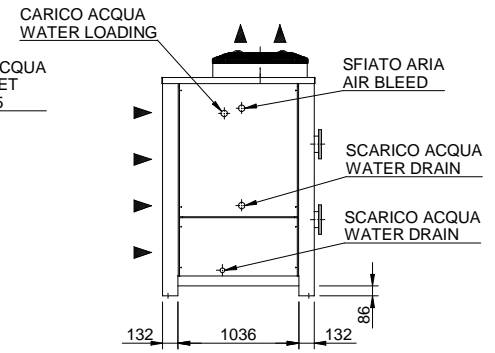

VISTA POSTERIORE
BACK VIEW

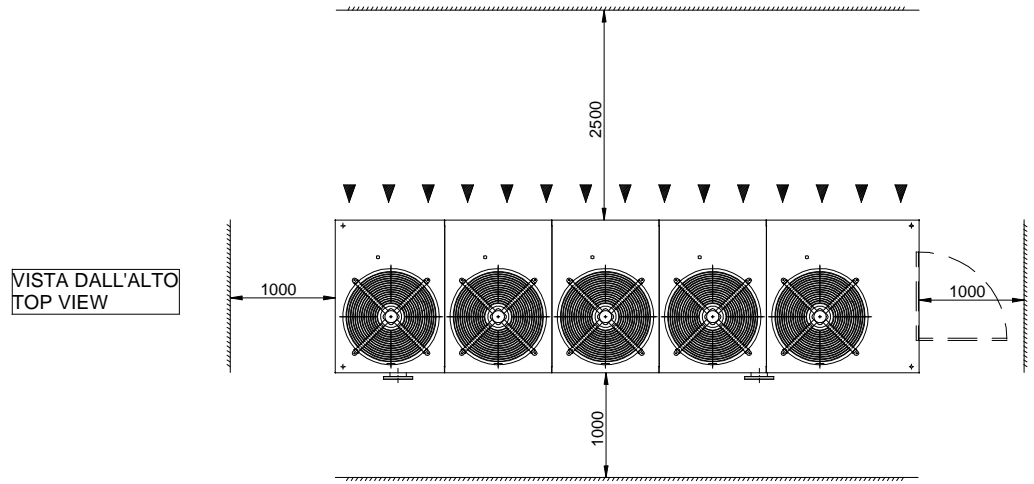

VISTA DALL'ALTO
TOP VIEW

PESO - WEIGHT
ECA.250 - 2350 Kg.
ECA.280 - 2730 Kg.

REFRIG.D'ACQUA / WATER CHILLERS mod.ECA.250/CS STT - ECA.280/CS STT
DIMENSIONI D'INGOMRO / OVERALL DIMENSIONS